



*Protective Linings for
Industrial Applications*

INSTALLATION MANUAL

CONTINUOUS LENGTH DUMP BODY LINERS

FOR USE WITH

RE-PRO Heavy Duty Rock Liners (8, 10, 12 Ft)
&
ECO-PRO Heavy Duty Rock Liners (8, 10, 12 Ft)
&
E-Z Medium Duty Economy Liners (8, 10 Ft)

-IMPORTANT-

Read through the ENTIRE Manual BEFORE INSTALLATION

MOUNTING TYPE

Front Float Mount

INTRODUCTION

Installation of a RE-PRO, ECO-PRO or "E-Z" Continuous Length Bedliner is easy when following the step-by-step instructions in this Manual. However, some important precautions must be taken to ensure a smooth installation. Pick the type Liner System and Options (if any) and locate section in this Manual for instructions and read thoroughly before starting job. AMLS is not responsible for improperly installed Liner Systems. **IF CROSS CONTAMINATION IS AN ISSUE...PLEASE CALL IMMEDIATELY BEFORE INSTALLING YOUR LINER.**

CHECK AND PREPARE DUMP BODY: Condition of Dump Body: The body should be structurally sound. If the bed is used and has deep valleys or dents between the ribs (3/4" or greater), they should be pounded up or patched ... please call your Service Representative if you have any questions. **Any holes and rips in the bed should also be patched.**

Clean Out Body: *THE BODY SHOULD BE CLEAN (SWEEPED OUT OR HIGH PRESSURE WASHED) PRIOR TO INSTALLATION. ANY UNUSUAL ATTACHMENTS TO THE FLOOR, DOGHOUSE OR WALL, SUCH AS SHOVEL HOLDERS, VIBRATORS, ETC., SHOULD BE REMOVED OR GROUND DOWN AS NEEDED.*

Aluminum Beds: *NO SPECIAL PREPARATION IS NEEDED BEYOND MEETING THE BED CONDITION CRITERIA DESCRIBED ABOVE. UNLESS CORROSIVE MATERIALS ARE HAULED. THEN FOLLOW STEPS FOR STEEL.*

Steel Beds: *STEEL BODIES SHOULD BE COATED WITH RUST PREVENTATIVE PAINT OR TAR BASED UNDERCOATING BEFORE LINER INSTALLATION TO PREVENT RUSTING.*

PREPARE FOR INSTALLATION

Check the Liner Kit: Your Kit will include the following:

- (1) Roll of Material.
- (1) Box of Hardware - Containing: Fasteners, Drill Bits, Counterboring Tool, and Silicone Sealant.
- (1) Package of Metal Edge Protectors - Aluminum or Steel (8ft Sections).
- (2) Flat Stocks

IMPORTANT: The Metal Edge Protectors are packaged separately from the pallet containing the Liner roll. Always check Liner contents when delivered. If any contents are missing, notify the carrier immediately.

Unroll The Liner: The Liner should be unrolled for at least 2-3 hours prior to installation. Put weights on the ends if needed. Every effort should be made to do the installation in a heated garage.

Temperature should be at least 75 degrees F.

Note: The warmer the liner material the easier the installation will be.

Manpower: Installation is usually a two-man job, though a third person would be helpful.

Get Tools Ready: You will need the following tools- (ALWAYS WEAR SAFETY GLASSES AND TAKE PROPER PRECAUTIONS WHEN USING TOOLS DURING INSTALLATION)

- | | |
|---|--|
| (1) Electric Circular Saw (Skillsaw) with a carbide or good steel blade | (1) Chalk Line |
| (1 or 2) Electric Drills 3/8" or larger | (1) Large Hammer |
| (*) Porta Power (Optional) | (1) Tape Measure |
| (1) Jig Saw or Sawsall | (1) Razor Knife |
| (1) Caulk Gun | (1) Piece of Cardboard (approx. 2' x 3') |
| (3 - 6) Cargo Jacks / Load Locks | (1) 2 Ft Carpenter Square |
| | (1) Pair Safety Glasses |

HEAT! HEAT! HEAT! HEAT! HEAT! HEAT! HEAT!

Have A Heated Garage: For installations during the winter, it is **VERY IMPORTANT** to have a heated garage (75 degrees or higher) or area to work in. If you have to work outdoors, we recommend tarping over the dump and using a torpedo or blow heater to keep the liner warm during installation, otherwise the Liner will bubble more during the summer months.

You're Ready To Start: With the necessary tools and material at hand, you are ready to start. For simplicity, the example used is the installation of a 16 ft Liner Kit.

LAYOUT DUMPBED & CUT OUT FOR DOGHOUSE

TOOLS NEEDED: Tape Measure, Razor Knife, Circular Saw, White Marker, Chalk Line

- (1) Measure the depth of the doghouse for dimension A. Measure the width of doghouse dimension B as shown in FIG #1.
- (2) Make a template for the nose (if required) by squaring a piece of cardboard to the front of the body and the doghouse. Force the cardboard to conform to any curvature in the front of the body. Use a razor knife to cut along the crease just made.
- (3) Using the Dimensions A & B from the doghouse, find center of sheet and cut out as shown in Figure #2. Cut opening about 1/4" to 1/2" larger on each side to allow for some expansion of material.
- (4) Using the cardboard template, place along "A" of sheet. Cut any curvature in plastic as needed.

REMEMBER: Don't cut sheet to length at this time — the sheet should be longer than the body. The Factory scores should be facing upward and line up with cleanouts, unless you have a cross-contamination issue, in which case you should contact your dealer or AMLS before installing. The ideal temperature is 75 - 80 degrees or warmer.

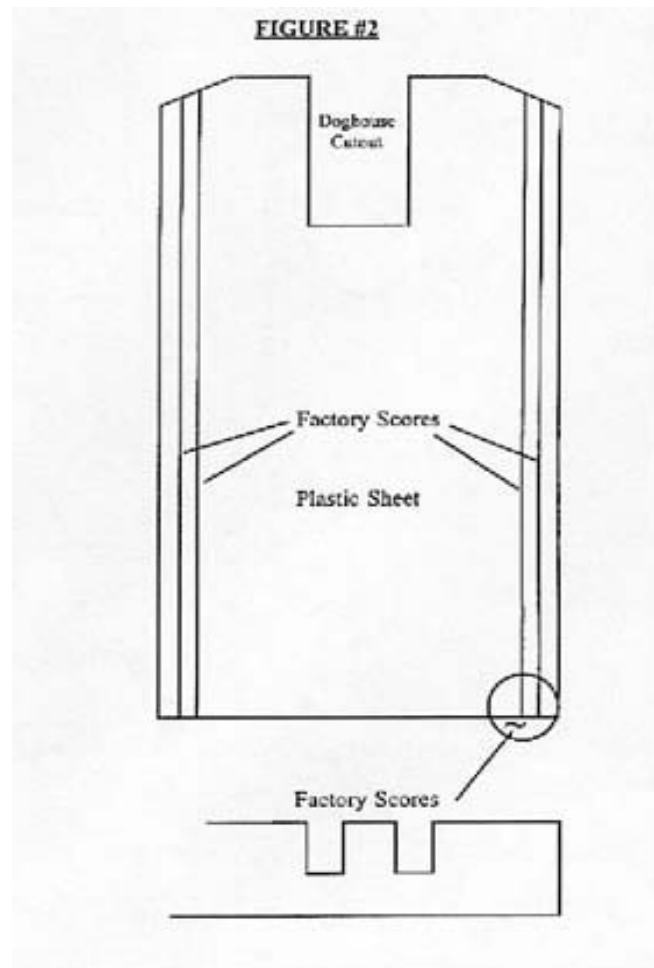
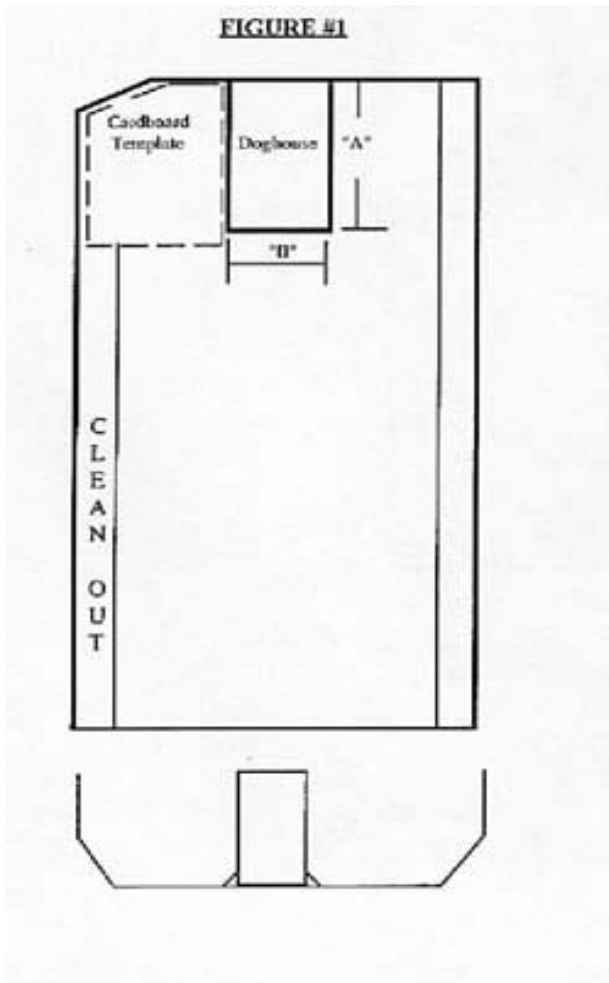

LAY IN LINER SHEET & CUTOUT FOR DOGHOUSE

TOOLS NEEDED: Silicone (supplied), Caulk Gun, Chalk Line, White Marker & Tape Measure

1. Lift Sheet into dump bed as shown below. It should be cut to allow about 1/4" around the perimeter of the doghouse. **This will be the time to trim the sheet if necessary.** Once sheet fits, pull it back if needed and complete Figure #2.

2. After any adjustments are made, clean the area around the front of body and lay a bead of silicone around the doghouse and perimeter of front of body. You may use two smaller beads of silicone instead of one heavy one.

Do Not Silicone the rear of Liner Sheet.

3. Refer to the Figure on the next page for fastening methods and pattern layout. Mark the sheet for the fasteners with a china marker. Call your AMLS representative if you have any questions regarding this step.

Silicone Here



COUNTERSINKING FASTENERS

Always leave 3/16" - 1/4" plastic when countersinking for fasteners so plastic does not pull over screws during high temperatures. Below is a diagram and chart showing the proper countersinking depth. Example of 3/8" thick material is used.

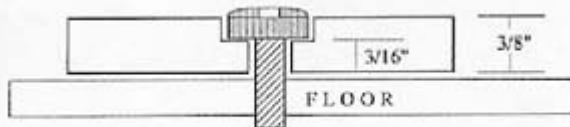

Liner Thickness	Depth of Countersink
1/4"	0" - 1/16"
3/8"	1/8" - 3/16"
1/2"	3/16" - 1/4"

FASTENER LAYOUT

TOOLS NEEDED: 3/8" Drill, Impact Wrench, Markers, Screws, Tape Measure

"FLOATING FRONT MOUNT SYSTEM"

This System works well when installing in cold weather situations. It is also beneficial if very fine materials are being hauled. Because fasteners are holding the Liner at the front of the dump body, it allows the sheet to remain relatively flat during temperature fluctuations. If you choose to install using this method, you can always add fasteners at a later date. With this method, you may notice a slight "winging" of the material at the back end due to the lack of fasteners as well as possible shifting of rear portion of Liner which may cause some warping. In addition, material can also gather under the rear section causing the need to clean out regularly. This system is not recommended for hauling very heavy materials.

Trailer Length	Cutback Liner From Tailgate	Staggered Rows of Fasteners in Front of Doghouse
Up To 20'	0.5"- 1.0"	1-2
21'To 34'	1.5"-2.0"	3-4
35' To 40'	2.5" - 3.0"	5-6

The above chart is to be used as a reference. Install temperature, Liner thickness, etc. can all have an effect on expansion.

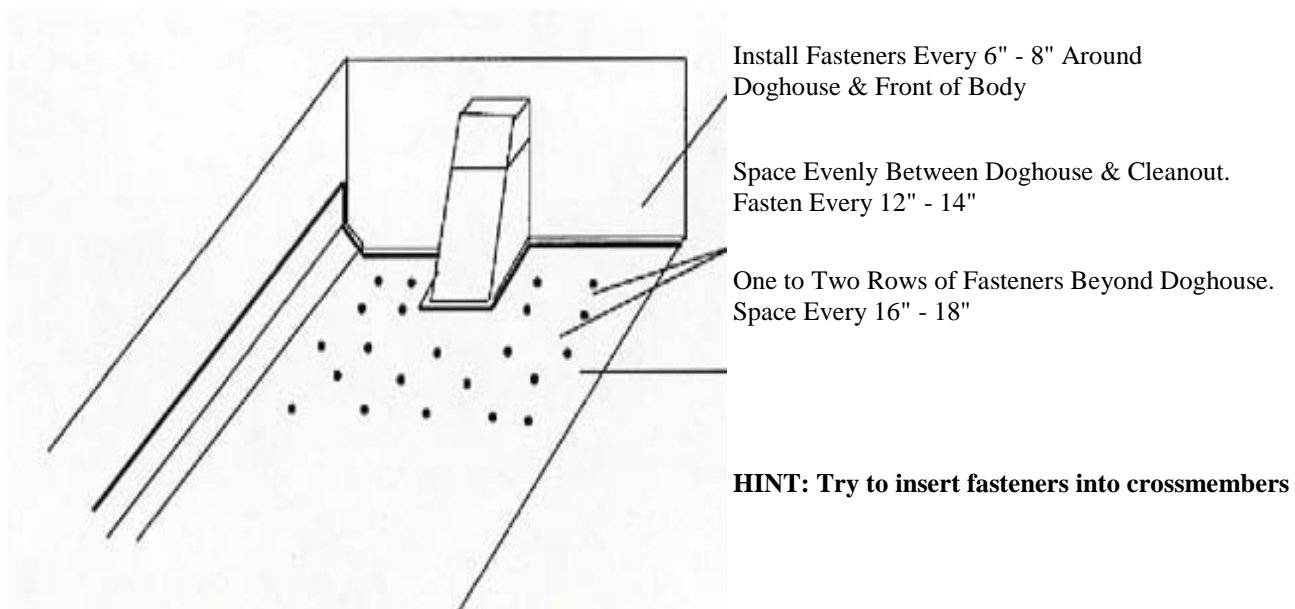

INSTALLATION INSTRUCTIONS

- (1) Install staggered rows of fasteners, per chart above, toward rear of body. Fasteners should be placed no more than 2ft to 8ft in front of doghouse.
- (2) Install 1 to 2 rows of fasteners along side of doghouse as shown.
- (3) It is very important to use a Porta-Power or other device to hold the plastic flat into the cleanout area and along the wall and floor while welding or bolting the Metal Edge Protectors supplied with the liner.

* **IMPORTANT** - *Cut the end of the liner at the tailgate shorter than the body per the chart above prior to fastening sheet.*

METAL EDGE PROTECTOR GUIDE

STANDARD COVERSTRIP (CVR)

Used as Doghouse, Wall Kits, Nosewrap, Tailgate Protectors.

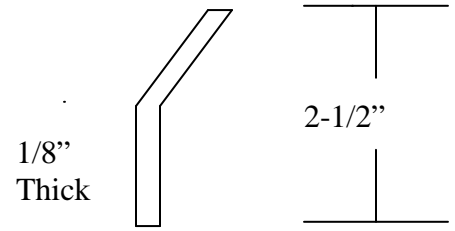

SINGLE PRONG COVERSTRIP (CVR-P-A)

Used as Liner Edge Protectors. This Coverstrip can also be bolted on rather than welded on. It also allows more room for plastic to expand. Single Prongs has replaced "Z" as standard with Kits.... Single Prong is approximately 1/4" thick.

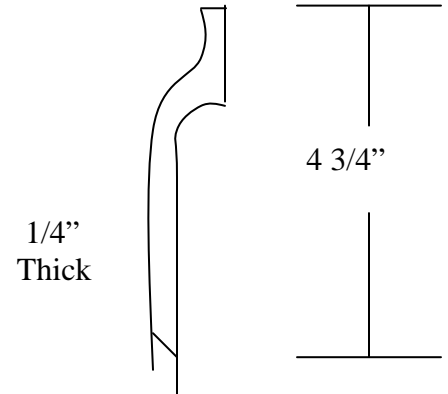

2" X 2" ANGLE (ANG)

Used for front of Doghouse.

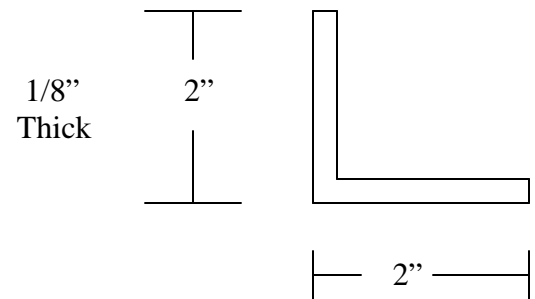

FLAT STOCK (FS-3)

Used in front of body and where curvatures exist.

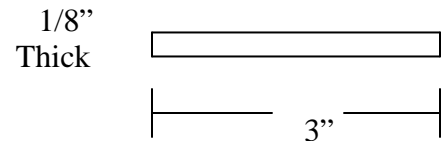

Metal Edge Protectors are a key component in the long term success of the Liner System. They help eliminate material infiltration around the Liner. If you are attempting an install yourself and do not have the welding capabilities, it is recommended to take your dump truck or trailer to a local weld shop and have the Metal Edge Protectors installed as shown on the following page.

INSTALL METAL EDGE PROTECTORS

INSTALL COVERSTRIPS TO WALL

1. Place Single Prong Coverstrip (CVR-P) along top edge of Liner as shown. Use the following procedure. Be sure Liner is forced all the way into cleanouts before welding CVR-P.
 - A. Start at rear of body. Have someone hold "CVR-P" in place while you "tack" in place. Be sure to leave approximately 1-1/2" under CVR-P for Liner expansion.
 - B. Butt 8 ft sections together and continue toward front.
 - C. Once tacking is complete, then either stitch weld or continuous weld entire length.

NOTE: If you are installing a Wall Kit you do not need to continuous weld... a stitch weld will be sufficient.

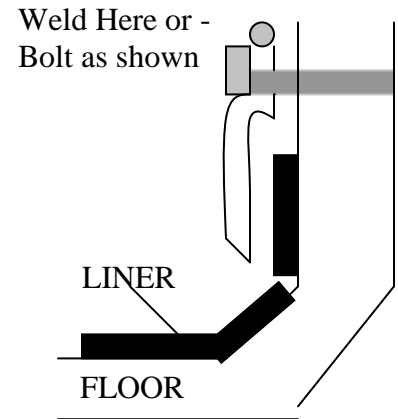

INSTALL COVERSTRIPS AROUND DOGHOUSE

1. Weld or bolt Flat Stock around bottom of Doghouse as shown below. Do the same for the front of Doghouse. Install Angle on corners of Doghouse.

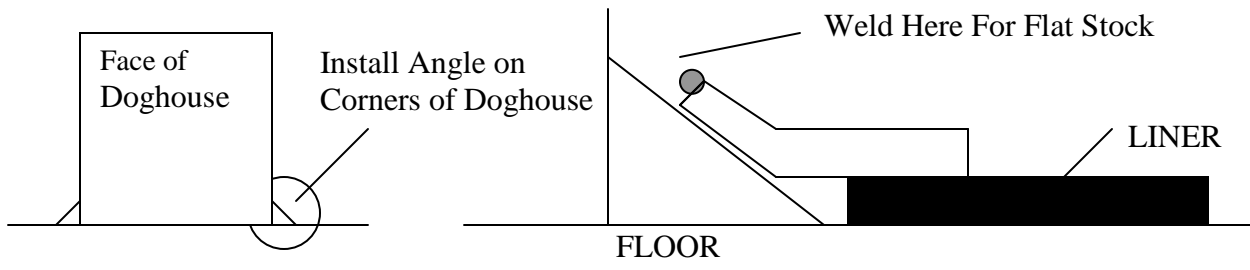

INSTALL FLAT STOCK AT FRONT OF BODY

1. Use Flat Stock for front of body as shown below.

